

Dynakit

FMA-2 INSERT AMPLIFIER

SERIAL NUMBER

This number must be mentioned in all communications concerning Dynakit.

ASSEMBLY INSTRUCTIONS

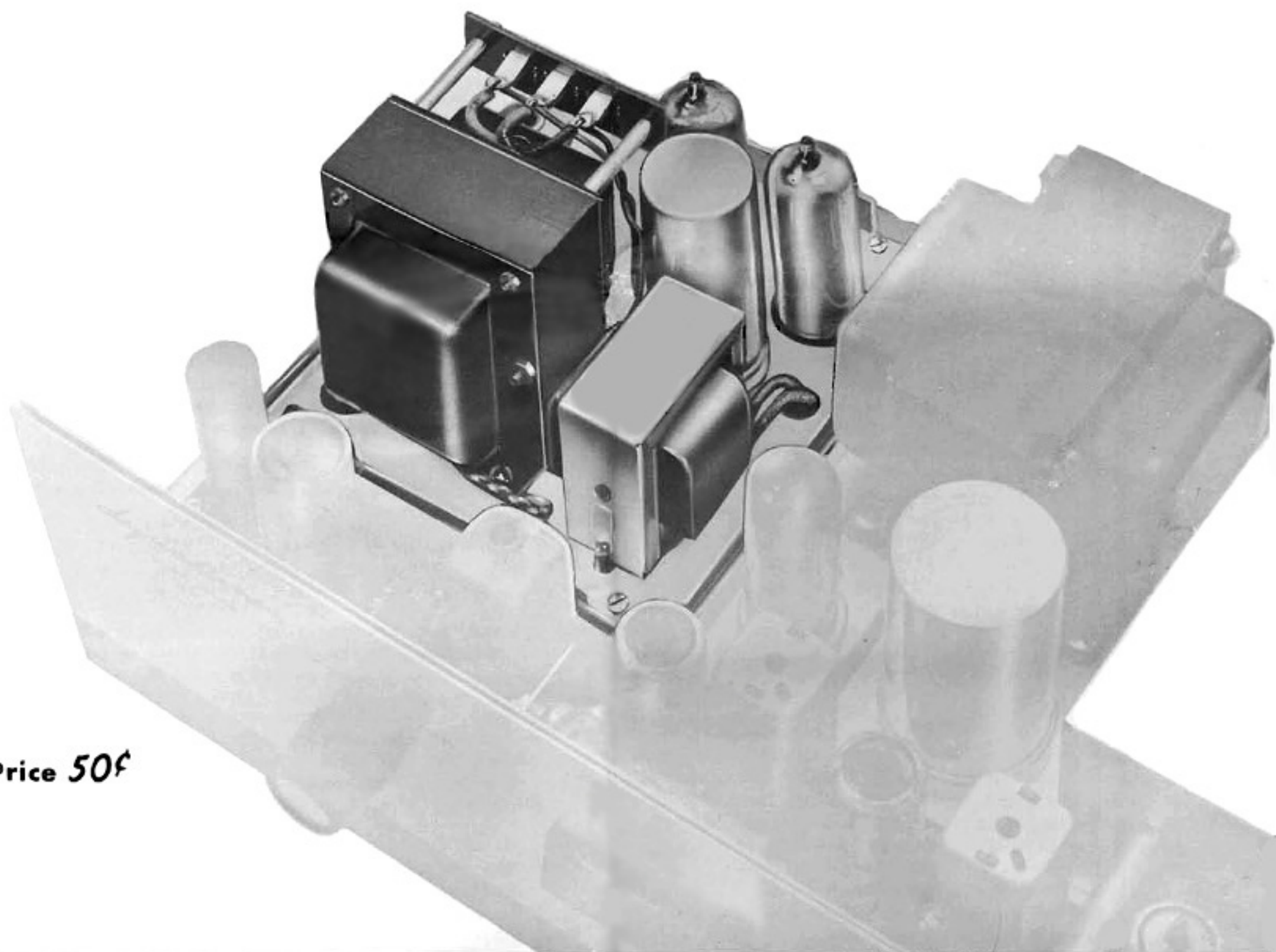

Price 50¢

DYNA COMPANY

DYNACO

**3916 POWELTON AVE.
PHILADELPHIA 4, PA.**

FMA-2 INSERT AMPLIFIER

DESCRIPTION

The Dynakit FMA-2 is a semi-selfpowered 10 watt amplifier designed to fit inside the FM-1 Dynatuner. It occupies the chassis cutout presently provided for the Dynaco multiplex adapter. This amplifier provides full high fidelity performance within its power rating, converting the Dynatuner into a complete FM radio (less loudspeaker). At the same time, the tuner can still function independently as an ultra sensitive, low distortion, wide band tuner.

The performance of the FMA-2 is on a quality level not normally found in amplifiers of low power rating. It provides 10 watts at less than 1% distortion within 1 db from 30 cycles to 15,000 cycles. Its frequency response is ± 1 db from 12 cycles to 35,000 cycles. Transient response is excellent, permitting clean transfer of 10,000 cycle square waves and critically damped low frequencies.

A unique power supply configuration borrows power from the present Dynatuner power supply, using additional silicon diodes to obtain a negative voltage. Operating voltages in the Dynatuner are unaffected by operation of the FMA-2 because the power supply of the FM-1 tuner was designed with extra load capacity. The 6BQ5/EL84 output tubes operate with the inverted power supply. A 12AX7 voltage amplifier and phase inverter stage uses the FM-1 power supply, an arrangement which completely eliminates undesired coupling between low and high level amplifier stages. The use of a miniaturized high quality output transformer of patented Dynaco design permits a high feedback factor and low distortion over a wide band.

The FMA-2 can be used with its own loudspeaker, while audio signals may be taken from the A output socket to feed an amplifier (with or without preamplifier) and another loudspeaker. It is also practical to use the Dynatuner to furnish signal to an external multiplex adaptor (see the Appendix of the FM-1 instruction manual) independently of the use of the FMA-2. There is no harm in removing the loudspeaker connected to the FMA-2 and using the Dynatuner in normal fashion. The amplifier is designed so that it can operate without a speaker connected.

ASSEMBLY

You will first assemble the etched circuit board, and then mount it and the other components on the chassis of your Dynatuner and complete the wiring. Note that the top of the etched circuit board diagrams the position of each component. The identification symbol for each part is marked between the holes into which its leads will be inserted. Resistors may be identified by comparing them with the color code provided on the parts list. The first color is nearest the end of the resistor, and any fourth color band should be ignored. Capacitors will be individually identified. Other special components will be identified as they are called for in the assembly process.

It is important that all components be mounted close to the board. Refer to the FM-1 instruction manual for detailed instructions on proper wiring and soldering techniques. A GOOD SOLDERING JOB IS ESSENTIAL TO THE PROPER PERFORMANCE OF YOUR RECEIVER. ALL SOLDERING MUST BE DONE WITH ROSIN CORE SOLDER. Whenever soldering is required, the instructions indicate it by "(S)". If this symbol is not shown after a connection is specified, it indicates that further connections will be made at that point before soldering.

When soldering a part to the etched circuit board, flow the solder from the lead onto the board so that no ball of solder is evident, but rather a smooth transition from solder to component lead, and to the board. The solder must completely surround the component lead. Do not apply excessive solder, but do not hesitate to apply sufficient heat to assure a smooth flow of solder all around the lead and onto the board. Be sure that all terminals are soldered to the copper on the board, as well as to the lead. Cut off all leads as close to the bottom of the board as possible, after soldering. This is essential, since the close confines of the tuner allow only $\frac{1}{4}$ " clearance from the board to the FMA-2 chassis.

PC-9 Etched Circuit Board Assembly

- 1() Mount all of the one-half watt resistors, R51 through R62, onto the board. Keep them flush against the board. Solder all leads and cut off the excess close to the board.
- 2() Mount the one-watt resistor R63 and the three-watt resistor R64. Solder each lead and cut off the excess close to the board.
- 3() Mount the small capacitors C51, C56 and C57. Keep them tight against the board. Solder each lead and cut off the excess.
- 4() Mount the rectangular capacitors C52, C53, C54, C55 and C58. Solder each lead and cut off the excess. The direction in which these capacitors face is not important.
- 5() Mount the connecting terminals #51 through #64. When the small end is inserted in the hole, they snap lightly into place. Solder each, and cut the excess off *on the bottom (copper side) of the board.*
- 6() Mount the three 9 pin sockets on top of the board. Note the orientation of the flat side of each socket. *Make sure each tab penetrates the board*, and bend the tips over for a secure mechanical connection. Solder each pin carefully. Note that in use, the tubes will plug into the bottom of the sockets, on the side of the board *opposite* to that on which other components are mounted.

- 7() Mount the two silicon diodes D51 and D52. *Be sure they are mounted with the polarity designation correctly oriented.* See the pictorial diagram. This determines the negative polarity of the FMA-2 power supply. When soldering the leads of the diodes, grasp the lead from above the circuit board with a pair of pliers while applying heat to the lead below the board. This "heat sink" will prevent excessive heat from damaging the internal element of the diode. Solder all four leads, and cut off the excess.

Chassis Assembly

- 1() The chassis plate is right side up when the edges bend upward. Orient the filament transformer F-561 so that the leads will pass through the proper holes as shown in the pictorial diagram. Fasten it in place with two sets of #6 lockwashers and nuts.
- 2() Mount the three screw terminal strip on the output transformer Z-499. Install it adjacent to the three short transformer leads, and orient the lugs as shown in the pictorial diagrams. The two $2\frac{1}{4}$ " #6 screws are inserted through the terminal strip, through the 1" spacers and into the upper transformer holes. The assembly is secured with two #6 lockwashers and nuts.
- 3() Mount the output transformer Z-499 on the chassis plate. Pass the transformer leads through the proper holes in the plate, and secure the transformer with four $\frac{1}{2}$ " #6 screws. Use 1 lockwasher and 1 nut for the two screws nearest the front edge (undimpled mounting holes) of the chassis plate. Use one lockwasher and 2 nuts for the screws through the dimpled holes. Tighten all screws securely.
- 4() Mount the dual-section electrolytic capacitor C59. Note the orientation of the two long center lugs as shown in the pictorial diagram. Grasp each of the three mounting tabs with a pair of pliers and twist one-quarter turn to secure the capacitor.

Final Assembly

In the final wiring stages, it will be necessary to solder to the previously installed connecting terminals. This will be easier if a small amount of solder is first flowed into the top of the terminal. Also, tin each wire first by heating it and allowing a small amount of solder to flow over the bared end. When soldering wires to the terminals, keep the iron near the upper edge to avoid loosening the connection below the board.

When interconnecting the FMA-2 and your Dynatuner, it will be necessary to solder to previously soldered connecting lugs in the tuner. To insert additional wires in already-soldered lugs, heat the lug first with the iron, and insert the wire while holding the iron to the lug.

Whenever a length of hookup wire is specified, strip $\frac{1}{4}$ " from each end unless otherwise indicated.

BEFORE STARTING WORK ON THE DYNATUNER, MAKE SURE THE LINE CORD IS DISCONNECTED FROM ANY SOCKET.

- 1() Remove the cover and bottom plate from the tuner. Remove the multiplex adapter cover-plate. Install the FMA-2 chassis-plate on top of the tuner chassis.

Use two sets of #4 hardware removed from the cover-plate to fasten the front edge of the FMA-2 plate (the edge nearest the front of the tuner). Use two $\frac{1}{2}$ " #6 screws to secure the rear edge of the FMA-2 plate. On each of the #6 screws, use one #6 lockwasher and two #6 nuts. Tighten all securely.

- 2() Connect one end of a 3" wire to the ground tab of the dual-section electrolytic capacitor as shown in the pictorial diagram. Keep this connection close to the chassis because of the tight clearance when the etched circuit board is installed (S). Run the other end of this wire to lug #2 of the three-lug terminal strip of the tuner. It is not necessary to solder this end yet.
- 3() Bend slightly upwards (toward you when looking at the bottom) the two long lugs of the output sockets A and B of the tuner. Mount the etched circuit board over the four rear #6 screws. Note that the two connecting lugs of the electrolytic capacitor come through the circuit board and that the black filament transformer leads run towards the fuse holder. Fasten the board in place with four additional #6 lockwashers and nuts.
- 4() Connect a 7" wire to lug #3 of the three screw terminal strip on the output transformer.
- 5() Connect the yellow transformer lead to lug #3 of the three screw terminal strip (S).
- 6() Feed the free end of the wire connected to lug #3 of the three screw terminal strip through the hole in the chassis and connect it to terminal #53 on the etched circuit board (S).
- 7() Connect the orange transformer lead to lug #2 of the three screw terminal strip (S).
- 8() Connect a 7" wire to lug #1 of the three screw terminal strip on the output transformer.
- 9() Connect the black transformer lead to lug #1 of the three screw terminal strip (S). Now push down on all 3 lugs of the 3 screw terminal strip, so that they will not contact the cover when it is installed.
- 10() Feed the free end of the wire connected to lug #1 of the three screw terminal strip through the hole in the chassis and run it to lug #2 (center) of the three lug terminal strip in the tuner. Connect this wire, the black wire from the mounting tab of the electrolytic capacitor, and the red lead from the output transformer to the center lug of the terminal strip and solder all three wires. There is a total of 7 wires connected to this lug.
- 11() Twist together the two black filament transformer leads and locate them toward the rear of the chassis as shown in the pictorial diagram. Connect one of these leads to lug #2 (side) of the fuse holder (S). Connect the other lead to lug #2 of the AC outlet (S).
- 12() Connect the blue output transformer lead to terminal #55 on the etched circuit board (S).

- 13() Connect the blue-white output transformer lead to terminal #61 on the board (S).
- 14() Connect either one of the green filament transformer leads to terminal #58 on the board (S).
- 15() Connect the other green filament transformer lead to the C59B lug of the electrolytic capacitor.
- 16() Strip a short piece of wire bare. Connect one end to terminal #59 on the board (S). Connect the other end to the C59B lug of the electrolytic capacitor (S). Make sure that this wire is short, so that it cannot touch the tuner bottom plate when it is installed.
- 17() Strip a second short piece of wire bare. Connect one end to terminal #60 (S). Connect the other end to the C59A lug of the electrolytic capacitor (S). Make sure that this wire is short, to avoid touching the bottom plate.
- 18() Connect one end of a 3 $\frac{1}{4}$ " wire to terminal #57 (S). Connect the other end to terminal #56 (S). This wire should be positioned close to the board.
- 19() Cut two 3" wires. Connect one end of one wire to pin #1 of socket V9 in the tuner (S). Connect one end of the other wire to pin #7 of socket V9 (S). Twist the two wires together, and connect one of the remaining ends to terminal #62 on the board (S). Connect the other end to terminal #63 (S).
- 20() Connect one end of an 8 $\frac{1}{4}$ " wire to lug #4 of the quadruple section filter capacitor in the tuner (S). Position the wire as shown in the pictorial diagram, and connect the other end to terminal #54 on the PC-9 board (S).
- 21() Connect one end of a 2 $\frac{3}{4}$ " wire to the center (long) lug of output socket A of the tuner (S), connect the other end of the wire to terminal #51 on the board (S).
- 22() Connect one end of a 6" wire to lug #1 of the three lug terminal strip in the tuner (S). There is a total of 7 wires connected to this lug. Connect the other end of the wire to terminal #52 on the board (S). Position the wire as shown in the pictorial diagram.
- 23() Connect one end of a 4 $\frac{1}{2}$ " wire to terminal #64 on the board (S). Connect the other end to eyelet #40 on the PC-8 board in the tuner (S). Be sure that the solder flows from the lead to the eyelet, and also from the eyelet to the board.

This completes the wiring of the FMA-2. It is wise to recheck your connections and make sure each component is in the correct location. One poor solder connection can upset the performance of your unit. Check to be sure that the position of the wires in the unit agrees closely with the pictorial diagram and the photographs. The pictorial diagram must necessarily be exaggerated for clarity, but any discrepancies between it and the photographs are of no

consequence. To make sure that no foreign bits of wire or solder are in the unit, it is suggested that you turn it over and shake it vigorously.

Remove the fuse presently in your tuner and insert the 2 amp fuse. Insert the 12AX7 tube in socket V51, and insert the 6BQ5/EL84 tubes in the V52 and V53 sockets. Your FMA-2 is now ready for operation. All that is required for a complete high fidelity system is a high quality speaker. The speaker leads are connected to the screw terminals on the output transformer. Loudspeakers from 4 to 10 ohms should be connected between screw terminals #1 and #2; loudspeakers from 12 to 20 ohms are connected between terminals #1 and #3. Install the bottom plate and tuner cover and secure with the 4 sheet metal screws. The speaker wires should be positioned to clear the up-turned edge of the FMA-2 plate, and out the corner of the tuner chassis.

IN CASE OF DIFFICULTY

The complete circuit of the Dynatuner FM-1 can be aligned and checked without use of the FMA-2. If the Dynatuner operates into an external amplifier, but signals are not normal from the FMA-2, this definitely isolates the problem to the FMA-2. If there are no tuner signals available from the output sockets, then the Dynatuner should be investigated first before attempting to service the FMA-2. Refer to the FM-1 manual for trouble-shooting assistance.

If problems are isolated to the FMA-2, then reference should first be made to the voltage chart. Departures of more than 20% from the values shown indicate that there is a problem in the portion of the circuit associated with the voltage reading.

In the event that the dual electrolytic capacitor is ever found to be defective, this cannot be replaced with a standard capacitor of the same value since it has a common positive lead whereas normal capacitors have a common negative lead. Replacements can be secured through Dynaco dealers or from the factory. However, if emergency field replacement is necessary, two separate insulated capacitors of corresponding rating can be used if the polarity is preserved (positive ends should be grounded to the chassis).

Hum in the FMA-2 may appear through the loudspeaker if one of the 6BQ5/EL84 tubes is defective, or if there is a severe unbalance between the two tubes. These should be replaced as a matched pair when tube replacement becomes necessary.

FACTORY SERVICE AND GUARANTEE

It is recommended that the entire tuner with FMA-2 installed be returned to the factory for service should service be required. Removal of the FMA-2 for servicing is generally not practical since its performance is interrelated with that of the Dynatuner, and both should be examined as an entity.

Please refer to the FM-1 manual for factory warranty and service on the FM-1. This section is applicable to the combined FM-1 and FMA-2 without additional charge for service of the amplifier portion of the circuitry.

Dyna Company assumes no responsibility or liability for damages or injuries sustained in assembly or operation of the FM-1 and/or FMA-2.

PARTS LIST

Parts of similar type which do not change performance may sometimes be included as a matter of expediency. This will account for slight variations in value and appearance.

1/2 watt resistors

R 51	27,000 ohms	red-violet-orange
R 52	150,000 ohms	brown-green-yellow
R 53	220,000 ohms	red-red-yellow
R 54	1,500 ohms	brown-green-red
R 55	470,000 ohms	yellow-violet-yellow
R 56	470,000 ohms	yellow-violet-yellow
R 57	47,000 ohms	yellow-violet-orange
R 58	47,000 ohms	yellow-violet-orange
R 59	470,000 ohms	yellow-violet-yellow
R 60	470,000 ohms	yellow-violet-yellow
R 61	470,000 ohms	yellow-violet-yellow
R 62	10,000 ohms	brown-black-orange

1 watt resistor

R 63	33 ohms	orange-orange-black
------	---------	---------------------

3 watt resistor

R 64	180 ohms	
------	----------	--

Capacitors

C 51	10 mmfd disc
C 52	.0068 mfd

C 53	.02 mfd
C 54	.02 mfd
C 55	.1 mfd
C 56	10 mmfd disc
C 57	220 mmfd
C 58	.068 mfd
C 59	40/40 mfd @ 350 volts electrolytic

1	12AX7/ECC83 — V51
2	6BQ5/EL84 — V52 and V53
1	PC-9 etched circuit board
3	9 pin socket for etched circuit board
2	silicon diode — D51 and D52
1	chassis plate
1	F-561 filament transformer
1	Z-499 output transformer
1	3 screw terminal strip
1	Fuse, 2 amp
1	piece hookup wire
1	Instruction Manual
1	Warranty Card

Hardware

6	#6/32 x 1/2" machine screws
14	#6 lockwashers
18	#6/32 nuts
2	1" sleeves for #6 screw
2	#6/32 x 2 1/4" machine screws

VOLTAGE CHECK POINTS

All voltages are measured between the point indicated and the chassis, using a vacuum tube voltmeter. All voltages are measured with the volume control at minimum. Voltages indicated by (*) must be measured only between the points indicated, as these points are -300 volts.

TUBE	PIN#								
	1	2	3	4	5	6	7	8	9
V 51 12AX7/ECC83	180	48	49	6.3 AC	6.3 AC	90	0	7	0
V 52 6BQ5/EL84	-305	-305	-295	6.3 AC*		-2	-5.5	0	0
V 53 6BQ5/EL84	-305	-305	-295	6.3 AC*		-2	-5.5	0	0

Terminal #52 6.3 AC
Terminal #55 -5.5
Terminal #59 -300

Terminal #58 }
to } 6.3 AC*
Terminal #59 }

Terminal #61 -5.5
Terminal #62 245 AC
Terminal #63 245

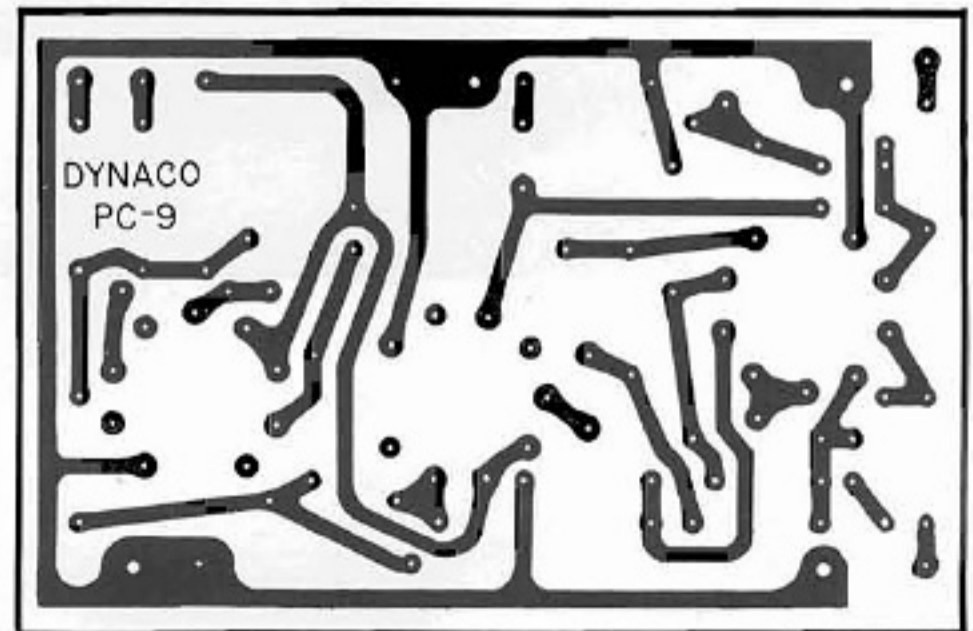
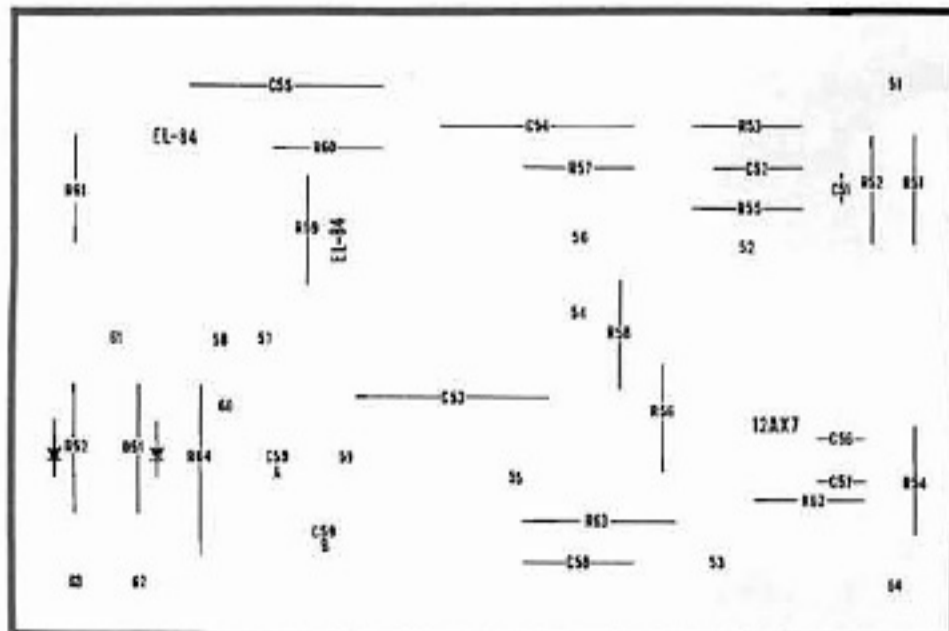

**PARTS LIST
FOR
SCHEMATIC DIAGRAM**

All resistors are 1/2 watt
10% unless otherwise
noted.

- R 51 27,000 ohms
- R 52 150,000 ohms
- R 53 220,000 ohms
- R 54 1,500 ohms
- R 55 470,000 ohms
- R 56 470,000 ohms
- R 57 47,000 ohms
- R 58 47,000 ohms
- R 59 470,000 ohms
- R 60 470,000 ohms
- R 61 470,000 ohms
- R 62 10,000 ohms
- R 63 33 ohms
1 watt
- R 64 180 ohms
3 watt

- C 51 10 mmfd disc
- C 52 .0068 mfd
- C 53 .02 mfd
- C 54 .02 mfd
- C 55 .1 mfd
- C 56 10 mmfd disc
- C 57 220 mmfd
- C 58 .058 mfd
- C 59 40/40 mfd
@ 350 v.

- D 51 silicon diode
- D 52 silicon diode
- V 51 12AX7/ECC83
- V 52 6BQ5/EL84
- V 53 6BQ5/EL84

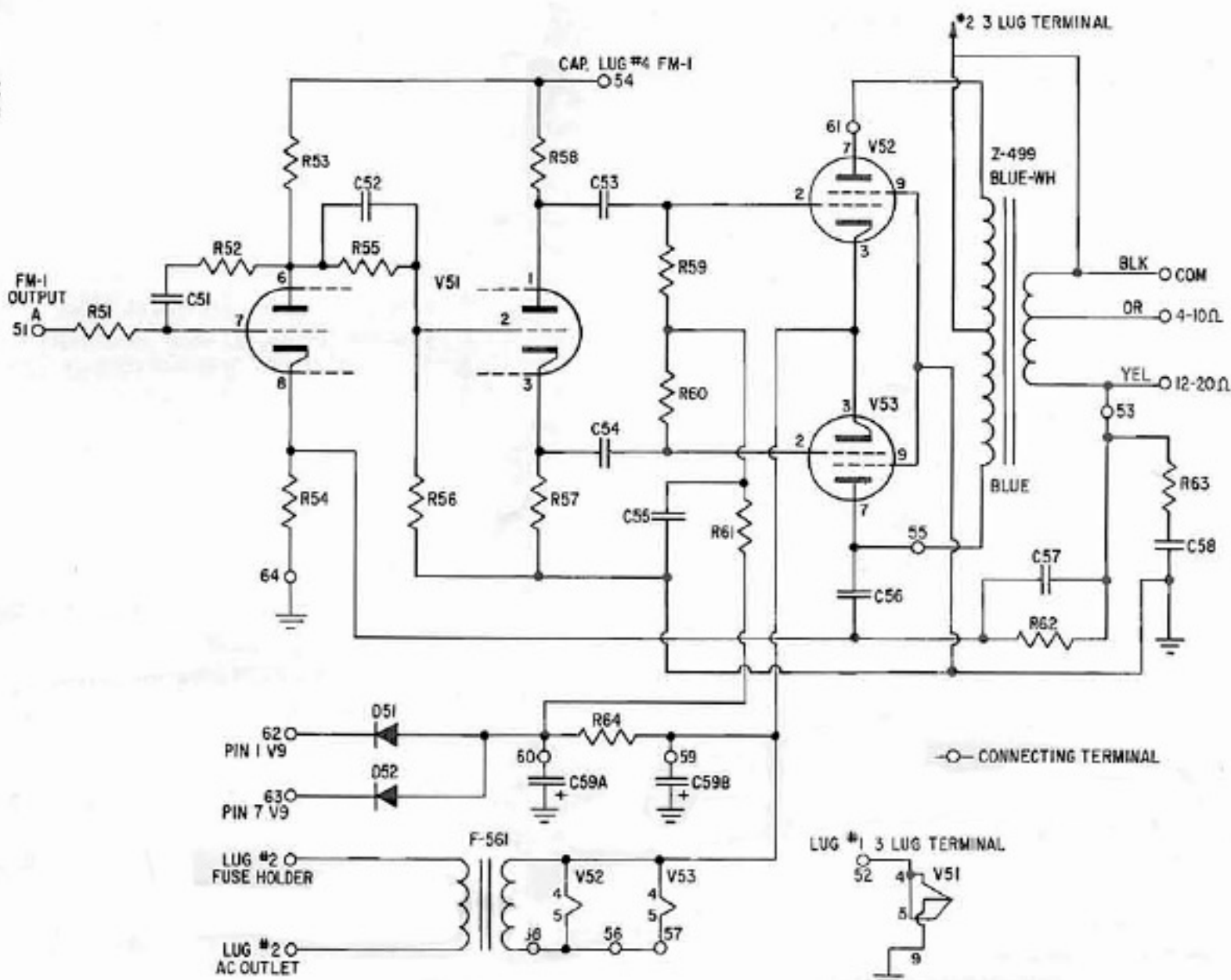

SCHEMATIC DIAGRAM

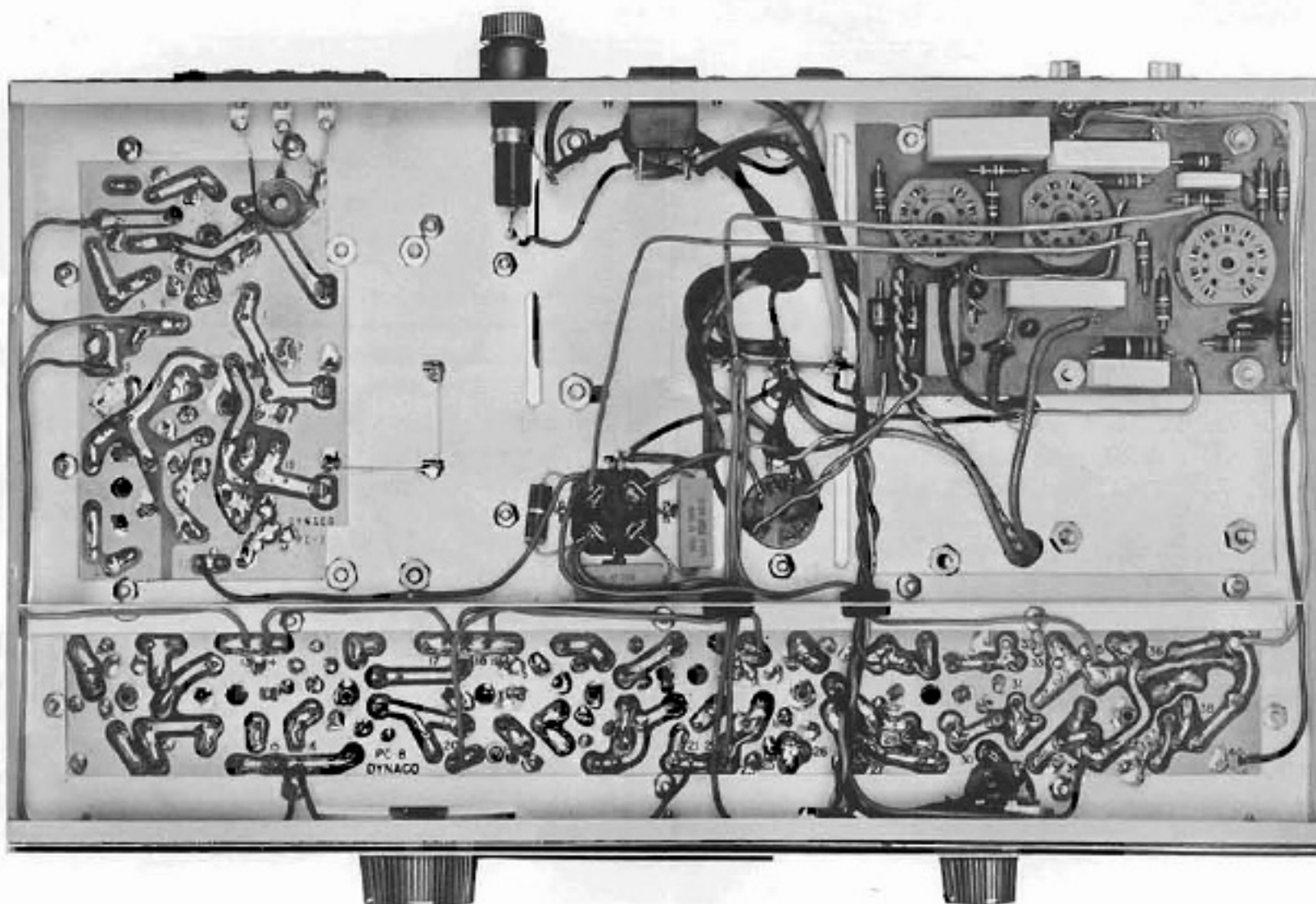

FUSE HOLDER

AC OUTLET

LINE CORD

A

B

